

Power connector	
1	U
2	V
3	W
GND	Ground
A	Fan (L) 220V
B	Thermal protection
C	Thermal protection
D	Fan (N) 220V
Signal connector	
1	S1
2	S2
3	S3 tacho
4	not used
5	S5
6	+24V DC
7	Ground

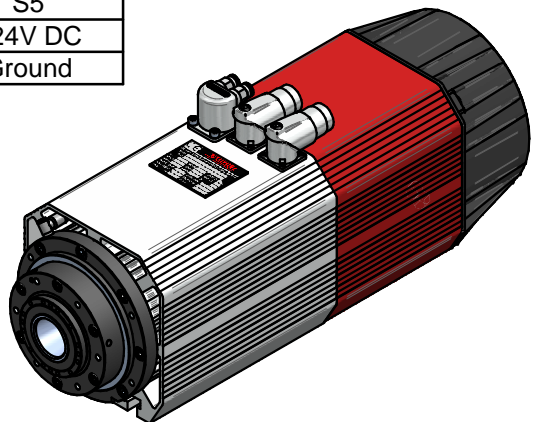

Type	Power S1/S6 [kW]	K	L	M
ATC71-A	3.8/4.6	180.5	429	191
ATC71-B	5.5/6.0	250.5	499	261
ATC71-C	7.5/9.0	250.5	499	261
Max speed [rpm]	Base speed [rpm]	Base voltage [V]	Base frequency [Hz]	
24000	12000	380	200	

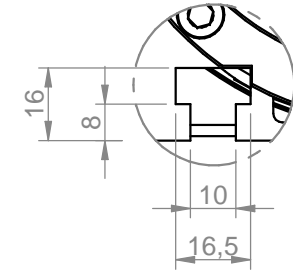
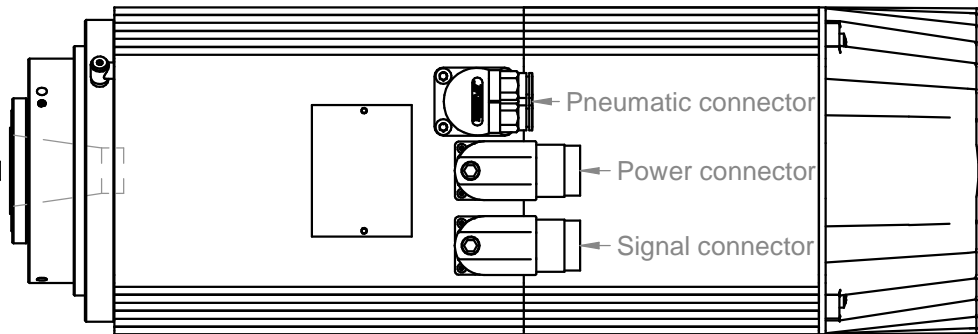
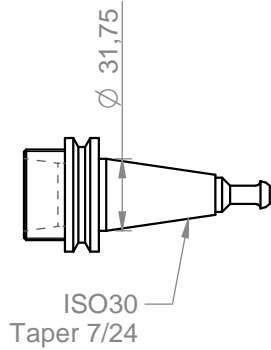

Teknomotor S.r.l.
Via Argenege 19, I-32030 Quero (BL)
www.teknomotor.com

Tolleranze non quotate: +0.5mm Smussi non quotati: +0.5mm	grado di equilibratura: 2.5 norma ISO 1940	$\nabla \nabla \nabla = 0.8 \nabla$	$\nabla \nabla = 3.2 \nabla$	$\nabla = 12.5 \nabla$	$\sim = \nabla$
--	---	-------------------------------------	------------------------------	------------------------	-----------------

titolo/title
ATC71 ISO30

Cliente/Customer
Catalogo

revisione n° 0	motivo di revisione Prima emissione			codice / drawing code 1TC000-001	disegno n° / drawing n°
--------------------------	---	--	--	--	-------------------------

dis. da / drawn Ing. Bottarel	appr. da / approved Ing. Perli	data / date 27/12/2012	sostituisce il sostituito dal	foglio / sheet 1 / 2	scala 1:2		A4
----------------------------------	-----------------------------------	---------------------------	----------------------------------	-------------------------	--------------	--	-----------